

UNIT 10 MEASUREMENTS OF VOLTAGE

(from Lillian C. McDermott and the Physics Education Group, *Physics by Inquiry Volume II, John Wiley and Sons*, NY, 1996)

Objectives

- to understand how to use a voltmeter to measure voltage
- to understand Kirchhoff's Second Rule

Equipment:

- 1 voltmeter
- 8 wires with alligator clips
- 2 bulbs
- 2 sockets
- 1 battery
- 1 battery holder

1.1 Potential difference is measured with a voltmeter in units of volts. The voltmeter is connected in parallel to the element whose voltage you wish to measure. If you wanted to measure the potential difference between the two ends of the battery, you would hook the voltmeter up as shown in the diagram below. We often call this the potential difference, or voltage, *across* the battery.

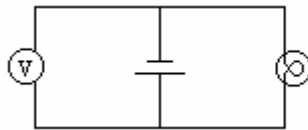

If you wanted to measure the potential difference between one point in a circuit and another, for example, points A and B, you would connect the voltmeter as shown in the diagram below.

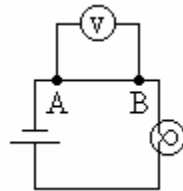

To measure the potential difference across a bulb, you would connect the voltmeter in parallel with the bulb.

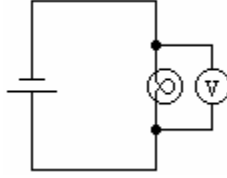

a. Set up a circuit with two bulbs as in the diagram below.

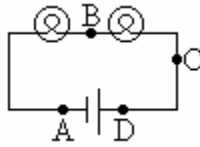

Measure the potential difference across the battery, each bulb, and the wires. Then measure the potential difference between points A and B, B and C, and points C and D.

The potential difference is the work per unit charge to move a charge from one point to another.

b. How does the potential difference across a wire compare to the potential difference across a bulb? Is this related to the idea that the bulb presents an obstacle, or a resistance to the flow? Explain.

c. Compare the potential difference across the battery to the potential differences across the other elements in the circuit in parts **a** and **b** above.

d. Discuss the force(s) doing the work to push positive charges through the circuit in the battery, in the bulb, and in the wires. Are all the forces electrical? Are the forces acting doing positive, negative or very little work in each of the elements? Does the potential energy increase, decrease or remain the same in different parts of the circuit? Explain.

Discuss part **d** with an instructor.

e. If you add up all the potential differences across the elements around the circuit, counting them as positive when the potential energy is increasing and negative when the potential energy is decreasing, what is the sum in part **a**?

Kirchhoff's Second Rule is that the sum of the potential differences around a closed loop is zero. Another way to state Kirchhoff's Second Rule is as follows: *The voltage across the battery in a current loop is equal to the sum of the voltages across the other elements.*

f. Is your data so far consistent with Kirchhoff's Second Rule? Explain.

Equipment:

1 voltmeter

- 8 wires with alligator clips
- 1 bulb
- 1 socket
- 1 10cm nichrome wire
- 1 20cm nichrome wire
- 1 30cm nichrome wire
- 1 40cm nichrome wire
- 1 battery
- 1 battery holder

2.1

a. Consider the circuit shown in the diagram below.

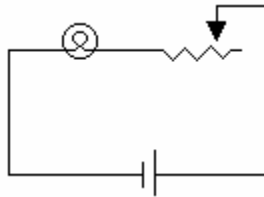

Predict the potential difference across the bulb when 0cm of nichrome wire is included in the circuit.

As the length of nichrome wire that is included in the circuit is increased, will the potential difference across the bulb increase, decrease, or remain the same? Explain your reasoning.

b. For lengths of 10cm, 20cm, 30cm of nichrome wire included in the circuit, record the potential difference across the battery, the bulb, and the wire.

c. Does your data in part b support Kirchoff's Second Rule? Explain.

d. As you increase the length of nichrome wire, the potential difference across the bulb decreases. What happens to the current through the circuit? Through the bulb? Why is there a decrease in potential difference in the bulb? Does the resistance of the bulb change?

e. If the resistance of an element (like the bulb in the above circuit) remains constant, but the current through the element increases or decreases, does the potential difference across the element change? Explain.

Equipment:

- 1 voltmeter
- 8 wires with alligator clips

- 1 bulb
- 1 socket
- 1 battery
- 1 battery holder

3.1 Consider the following circuits.

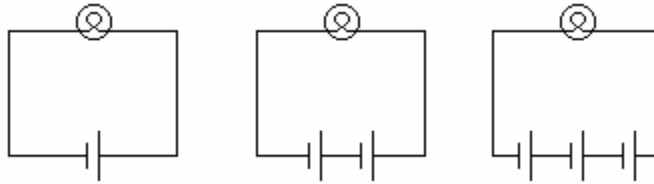

- a. If the potential difference across each of the batteries is known, determine the potential difference across the bulb in each of the three cases.
- b. Predict the relative current through (brightness of) each of the bulbs.
- c. Set up the circuits, use a voltmeter to verify part **a** and test your prediction in part **b** by observing the brightness of the bulbs.
- d. If the resistance of an element (like the bulb in the above circuit) remains constant, but the potential difference across the element increases, does the current through the element increase, decrease, or remain the same? Explain.

Equipment:

- 1 voltmeter
- 8 wires with alligator clips
- 1 20cm nichrome wire
- 1 30cm nichrome wire
- 1 40cm nichrome wire
- 1 battery
- 1 battery holder

4.1 Consider the following circuit.

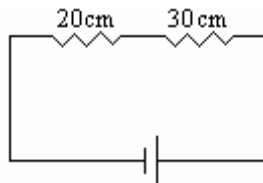

- a. Is the current through the 30cm length of nichrome wire greater than, less than, or equal to the current through the 20cm length of nichrome wire? Is the resistance of the 30cm length of nichrome wire greater than, less than or equal to the resistance of the 20cm length of nichrome wire. Predict the relative potential difference across each of the wires. Explain.

b. Set up the circuit and use a voltmeter to test your predictions.

c. If the 30cm length of nichrome wire were replaced by a 40cm length of nichrome wire, would the current through the 40cm length of nichrome wire be greater than, less than or equal to the current through the 20cm length of nichrome wire? How do the resistances of the two wires compare? Measure the potential difference across the battery and predict the potential differences across each of the wires.

d. Measure the potential differences across each of the wires and test your predictions.

e. For two elements in a circuit that have the same current passing through them, but different resistances, how are their potential differences related? Explain.

Equipment:

- 1 voltmeter
- 8 wires with alligator clips
- 3 30cm nichrome wire
- 1 battery
- 1 battery holder

5.1 Consider the following circuit of a 30cm length of nichrome wire in series with a parallel network of two 30cm lengths of nichrome wire.

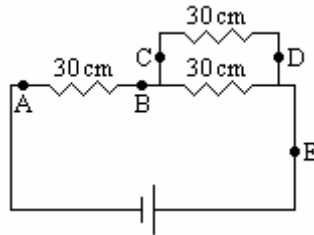

a. Predict the potential difference across the parallel network of two 30cm lengths of nichrome wire compared to the single 30cm length of nichrome wire. If you were to place the leads of the voltmeter at points C and D, how would the reading of the potential difference compare approximately to the reading of the potential difference measured with the voltmeter connected at points A and C? Explain.

If you were to place the leads of the voltmeter at points B and E, how would the potential difference compare to the voltmeter reading at points C and D? points A and C?

b. Set up the circuit and test your predictions. How would you measure the potential differences across the parallel network? How do the potential differences across the wires in parallel compare to the potential difference across the single 30cm wire? To each other?

c. Does Kirchoff's Second Rule hold in this case? Explain.

d. What does “around a closed loop” mean in Kirchhoff’s Second Rule? Explain.

Discuss your understanding with an instructor.

Equipment:

- 1 voltmeter
- 8 alligator clips
- 1 bulb
- 1 socket
- 3 batteries
- 3 battery holders

6.1 Set up the following circuits.

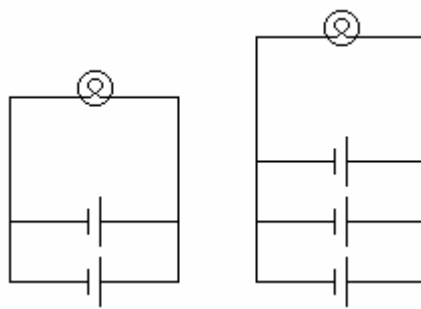

a. Compare the brightness of the bulb in each circuit to the brightness of a bulb in a circuit with one battery.

b. How do the currents through each of the bulbs compare? How do the currents through each of the batteries compare to the current through the battery in a single battery circuit? Explain your reasoning.

c. Why do children’s toys often require a number of batteries in parallel? Explain.

Equipment:

- 1 voltmeter
- 8 alligator clips
- 2 bulbs
- 2 sockets
- 3 batteries
- 3 battery holders

6.2 Consider the following circuit.

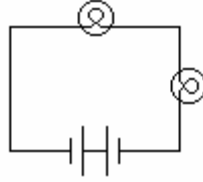

- a. Will the bulbs light? Explain your reasoning.
- b. Set up the circuit and test your prediction.
- c. Predict what would happen if a third battery were added. Explain your reasoning.
- d. Set up the circuit and test your prediction.
- e. Does Kirchhoff's Second Rule apply in these cases? Explain.

Discuss your understanding with an instructor.

SUMMARY

You should understand how to use a voltmeter to measure voltage. You should understand Kirchhoff's Second Rule.